

ULTRASOUND in MEDICINE

Human ears respond to sound in the frequency range of about 20 to 20000 Hz, medical engineers developed techniques for using ultrasound for diagnosis. Basically, an ultrasound source sends a beam of pulses of 1 to 5 MHz sound into the body. The time required for the sound pulses to be reflected gives information on the distances to the various structures or organs in the path of the ultrasound beam.

There are several methods of generating ultrasound. The most important for medical applications involves the piezoelectric effect. Many crystals can be cut so that on oscillating voltage across the crystals will produce a similar vibration of the crystal, thus generating a sound wave.

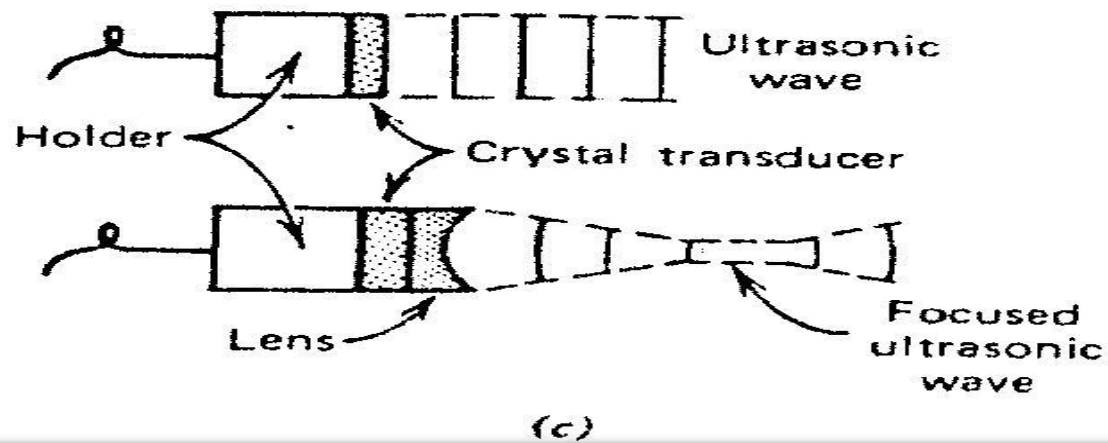
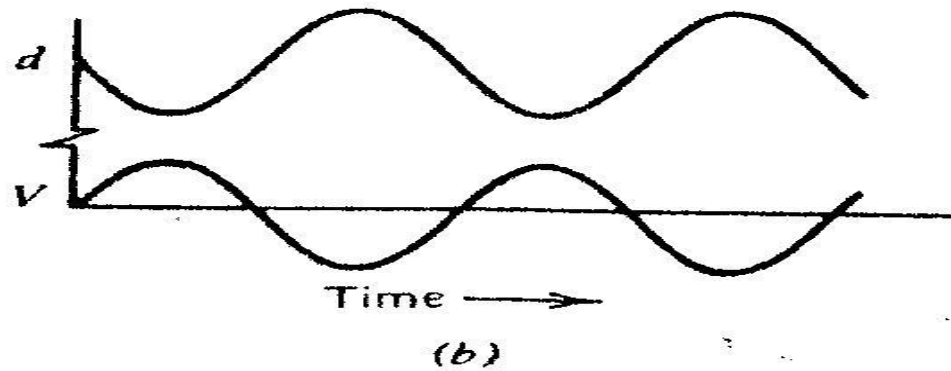
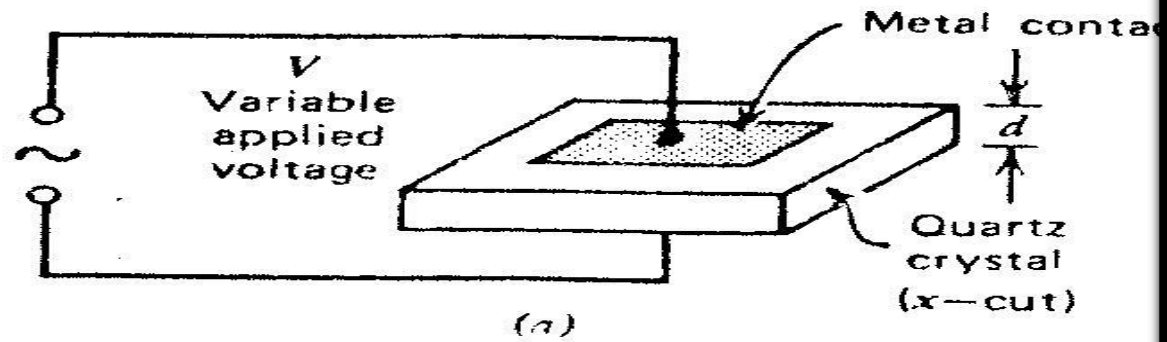

A device that converts electrical energy to mechanical energy or vice versa is called a transducer. Each transducer has a natural resonant frequency of vibration. The thinner the crystal, the higher the frequency at which it will oscillate. For a quartz crystal cut long a certain axis (X – cut), a thickness of 2.85 mm gives a resonant frequency of about 1 MHz. Typical frequencies for medical work are in the 1 to 5 MHz range.

Pulses of ultrasound are transmitted into the body by placing the vibrating crystal in close contact with the skin, using water or a jelly past to element the air. This gives a good coupling at the skin and greatly increases the transmission of the ultrasound into the body and of the echoes back to the detector. The vibration of the crystal produced by the echoes generate a voltage across it – the signals are displayed on an oscilloscope.

. Many of applications of ultrasound in medicine are based on the principles of sonar. In sonar a sound wave pulse is sent out and is reflected from an object, from the time required to receive the echo and the known velocity of sound in water, the distance to the object can be determined. This procedure is called the A-scan method of ultrasound diagnosis; pulses for A-scan work are typically a few microseconds long. They are usually emitted at 400 to 1000 pulse/s.

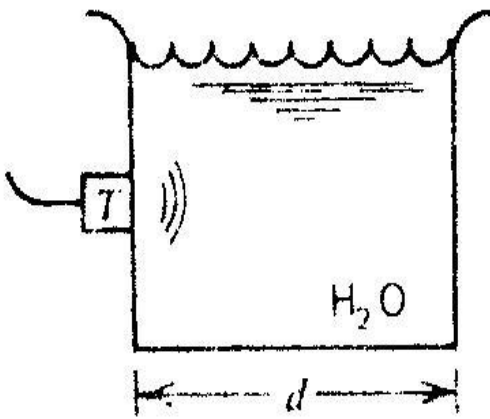

(a)

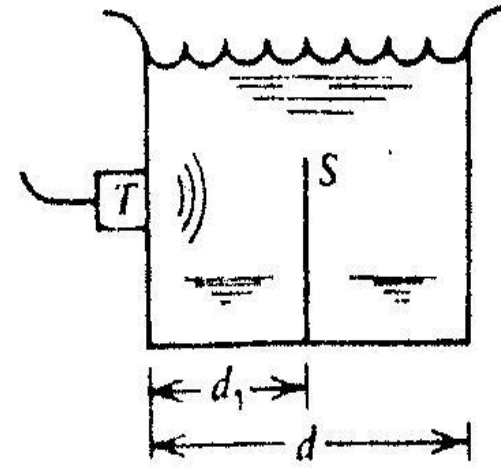

(b)

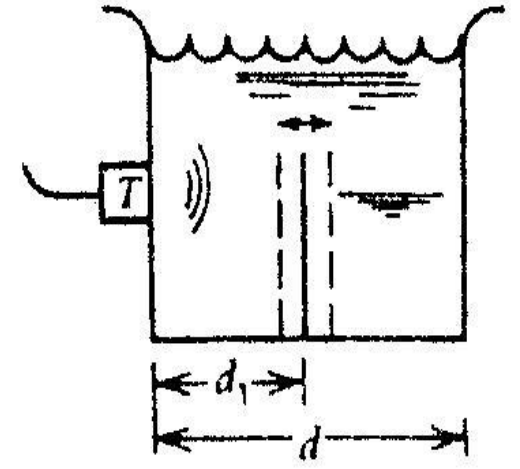

(c)

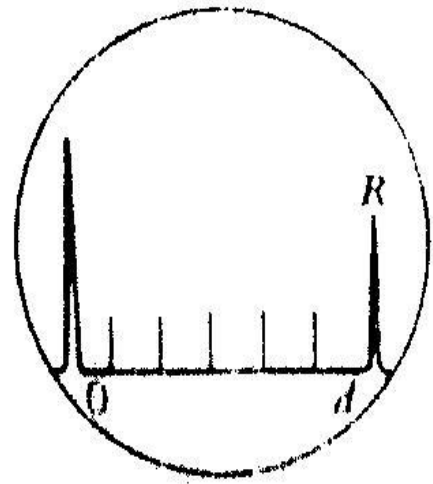

Oscilloscope

(a')

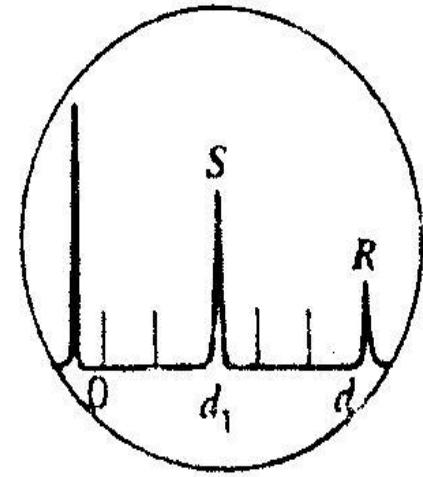

(b')

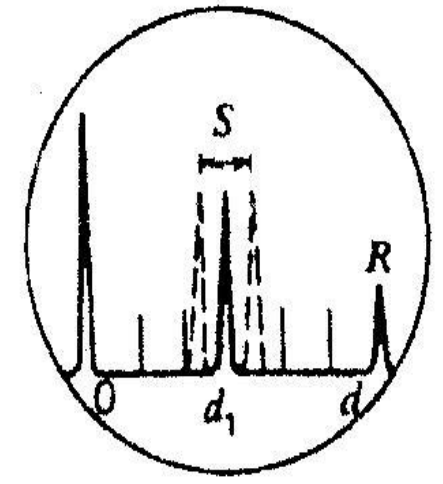

(c')

In(Fig a). a transducer **T** sends a pulse of ultrasound through a beaker of water of diameter **d**. The sound is reflected from the other side of the beaker and returns to the transducer, which also acts as a receiver. The detected echo is converted to an electrical signal and is displayed as the vertical deflection **R** on the cathode ray tube (CRT) of an oscilloscope, fig a' since the echo has been attenuated by the water, **R** is smaller in amplitude than the initial pulse shown in the oscilloscope at **0**.

In object in the beaker can be located with ultrasound. In (**Fig b**) a surface **S** at a distance **d1** produces an additional echo. Which displayed on the oscilloscope as **S** at the position **d1** (**Fig b'**). Note that the echo **R** is now smaller. When the surface vibrates (**Fig c**), the position of the echo on the oscilloscope also moves **Fig c'**

It is also possible to have multiple reflections between surfaces. A pulse emitted at the transducer T is reflected from the far side and returns to the transducer, where a part is converted to a signal and a part is again reflected to the far side: this part returns to the transducer again and appears as a signal. Such a multiple echo appears in (Fig b) as an object at a distance d and a second object at $2d$.

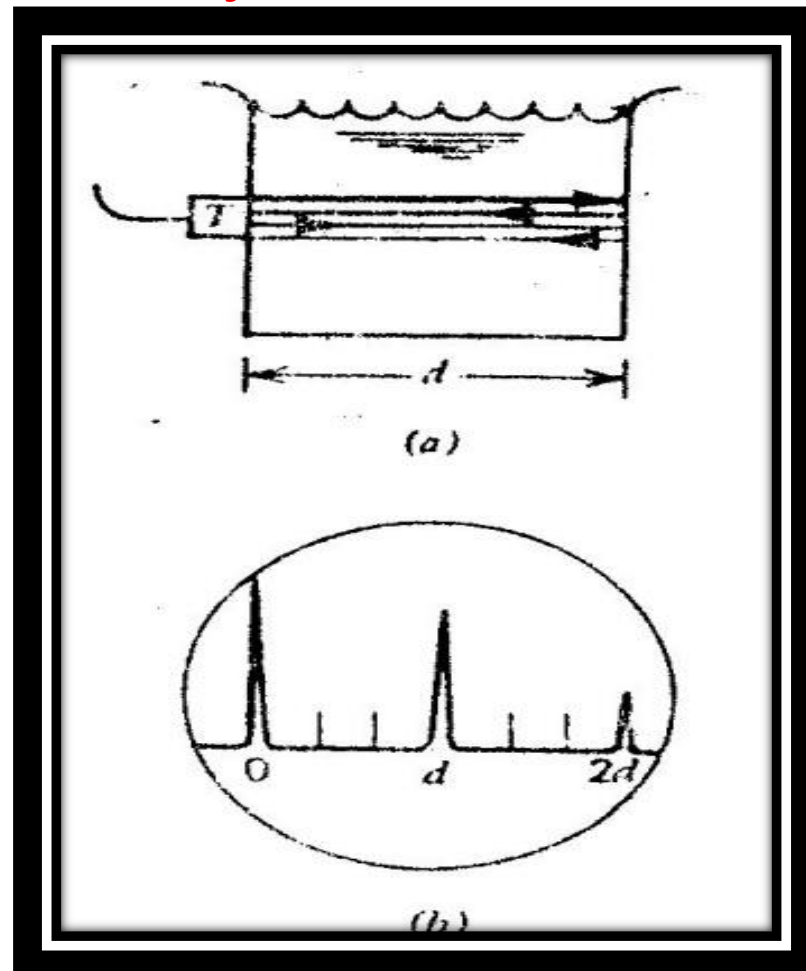

Another problem is the lack of resolution. Or the ability of the equipment to detect separate echoes from two objects close together. In general, structure smaller than the wavelength λ can not be resolved.

Since : $\lambda = V / f$

Where V is the velocity of sound and f is the frequency, the high frequency sound has shorter wavelengths and allows better resolution than low frequency sound. Since the absorption increases as the frequency increases.

One scan procedure echo encephalography, has been used in the detection of brain tumors. Pulses of ultrasound are sent into thin region of the skull slightly above the ear and echo from the different structures with in the head are displayed on an oscilloscope. The usual procedure is to compare the echoes from the left side of the head to those from the right side and to look for a shift in the midline structure.

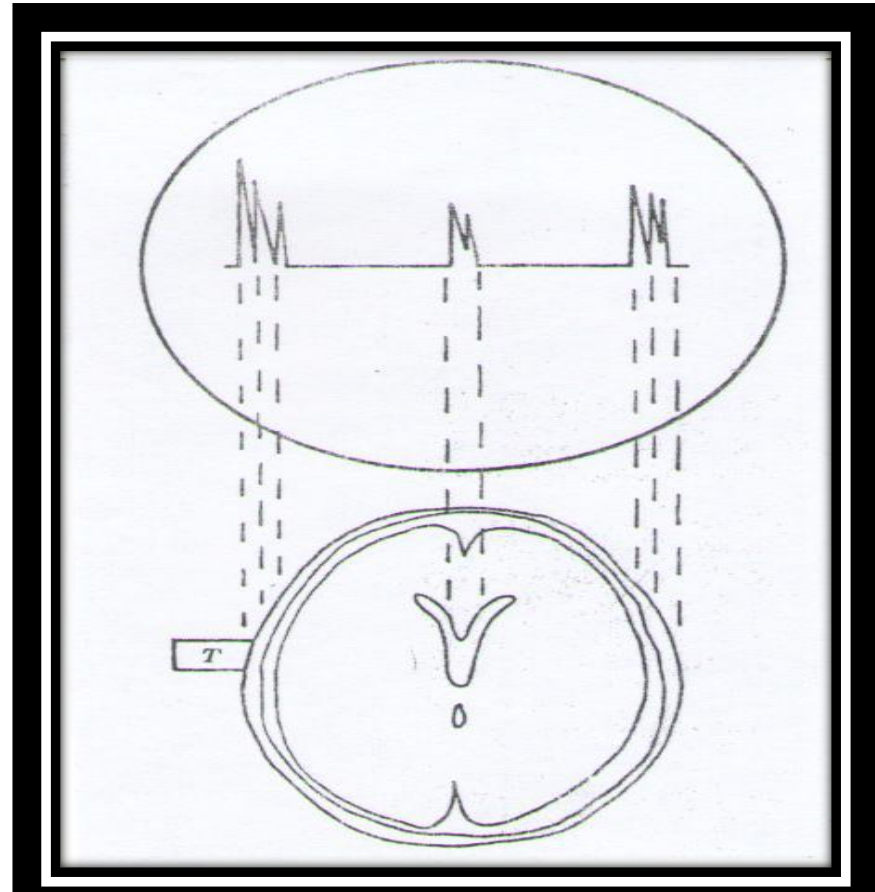

An ultrasound transducer T transmits sound through water into eye, and the reflected sound is displayed on an oscilloscope. It is possible to measure distance in the eye such as lens thickness, depth from cornea to the lens the distance to the retina.

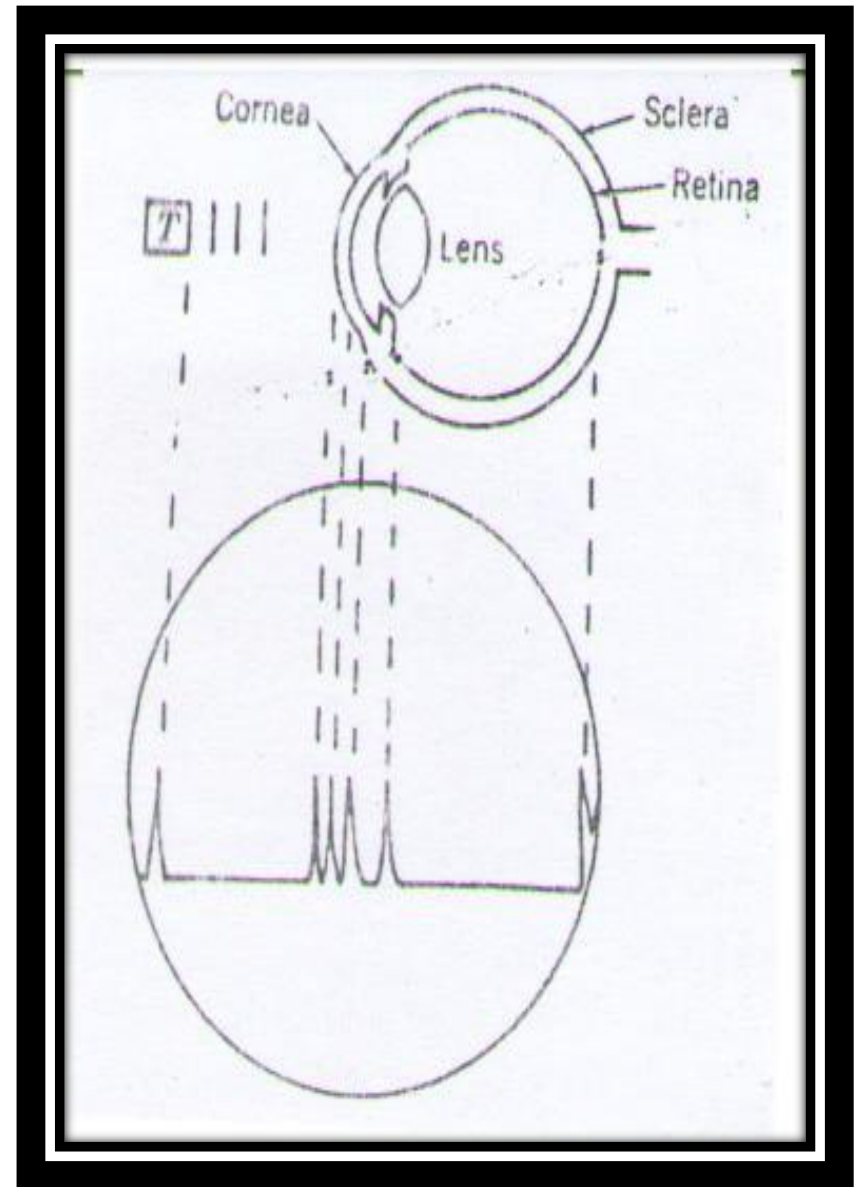

The B scan method is used to obtain two-dimensional views of parts of the body. The principles are the same as for A scan except that the transducer is moved as result each echo produces a dot on the oscilloscope at a position corresponding to the location of the reflection surface

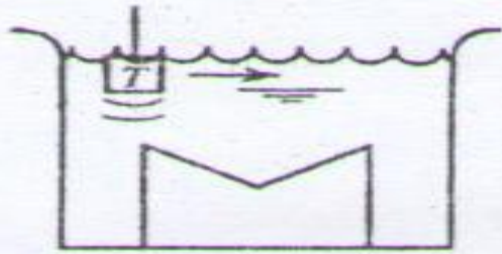

(a)

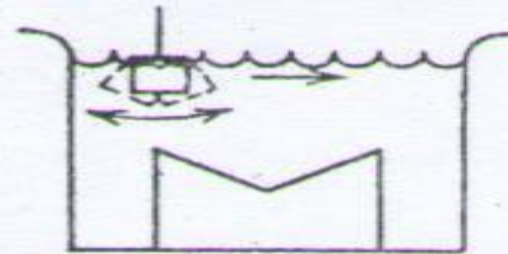

(b)

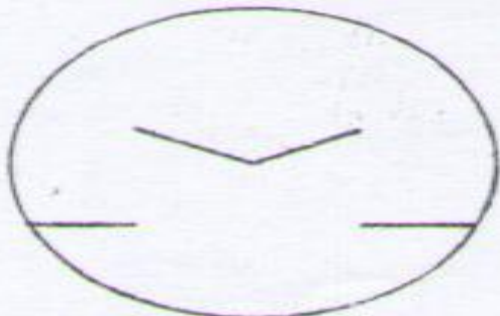

(a')

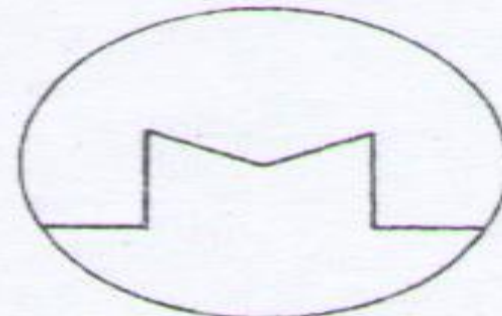

(b')

B scan provide information about the internal structure of the body. They have been used in diagnostic studies of the eye, liver, breast, heart and fetus. They can detect pregnancy as early as the fifth week.

ULTRASOUND TO MEASURE MOTION

- **Two methods are used to obtain information about motion in the body with ultrasound: the M scan, which used to study motion as that of the heart and the heart valves, and the Doppler technique, which is used to measure blood flow.**
- **The M scan combines certain features of A scan and B scan. The transducer is held stationary as in the A scan and the echoes appear as dots in the B scan.**
- **M scan are used to obtain diagnostic information about the heart. The rate of closing for a normal valve is indicated by the slope.**
-

The frequency change is called the Doppler shift. When the sound source is moving toward the listener or when he is moving toward the source, the sound waves are pushed together and he hears a frequency higher than f_0 . When the source is moving away from the listener or when he is moving away from the source, he hears a frequency lower than f_0 .

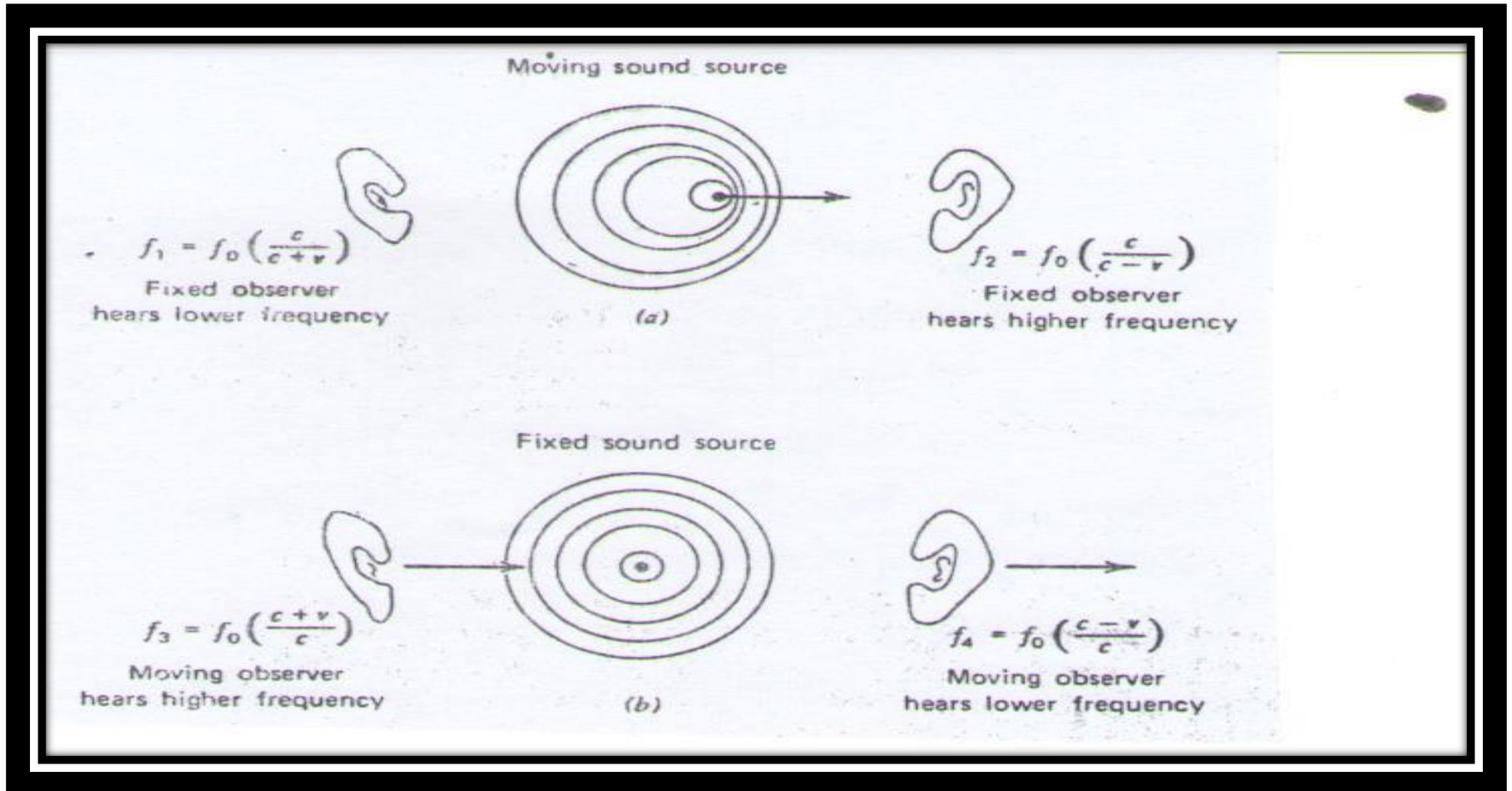

The Doppler Effect can be used to measure the speed of moving objects or fluids within the body, such as the blood.

When the blood is moving at an angle θ from the direction of the sound waves, the frequency change f_d is

$$f_d = \frac{2f_0 V}{\gamma} \cos \theta$$

Where f_0 is the frequency of initial ultrasound wave

V is the velocity of blood

γ is the velocity of sound

θ is the angle between V and γ

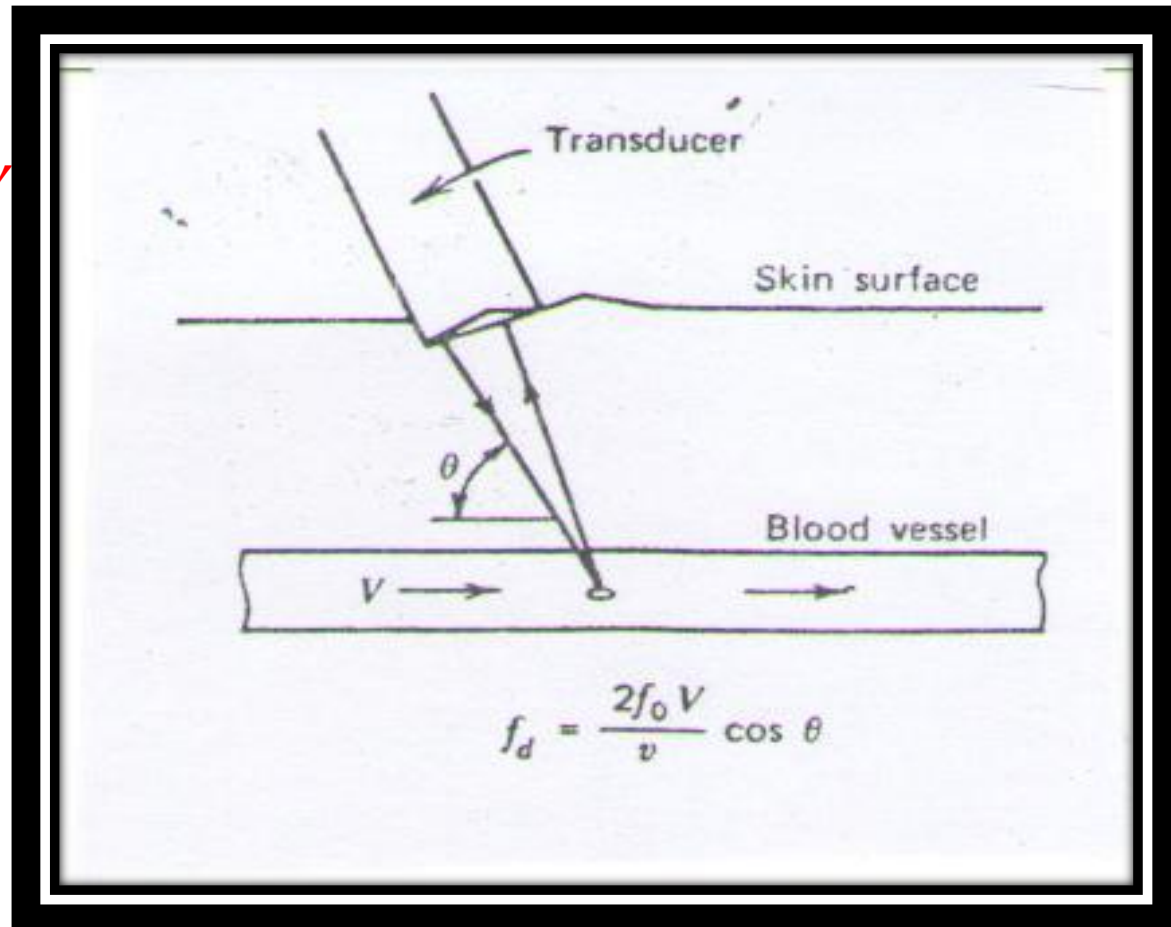

The Doppler Effect is also used to detect motion of the fetal heart, when a continuous sound wave of frequency f_0 is incident upon the fetal heart, the reflected sound is shifted to frequencies slightly higher than f_0 when the fetal heart is moving toward the source of sound and slightly lower than f_0 when the fetal heart is moving away from it. Variations in the frequency give the fetal rate.

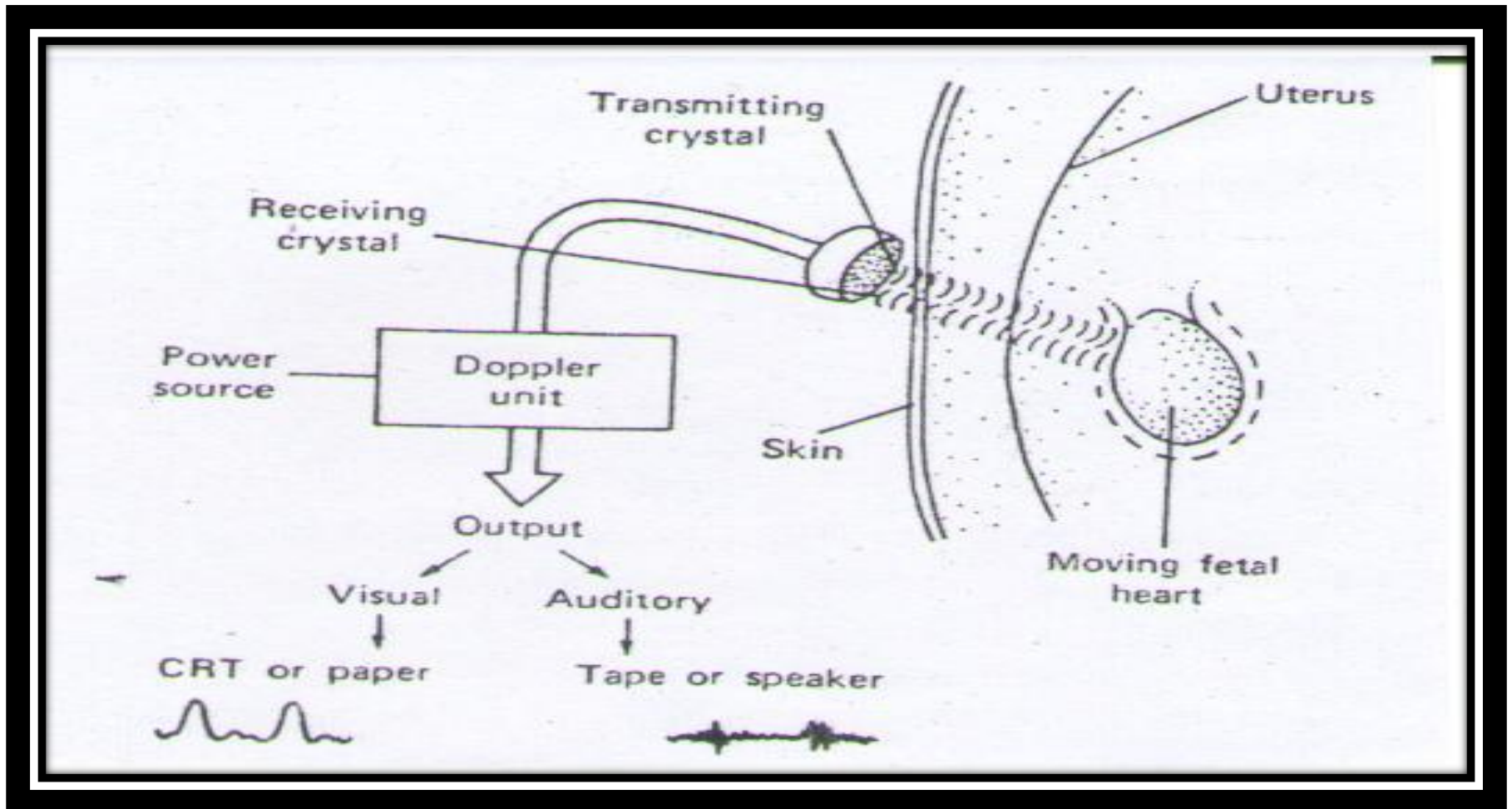

The most common use of the Doppler effect in obstetrics is in locating the point of entry of the umbilical cord (artery) into placenta.

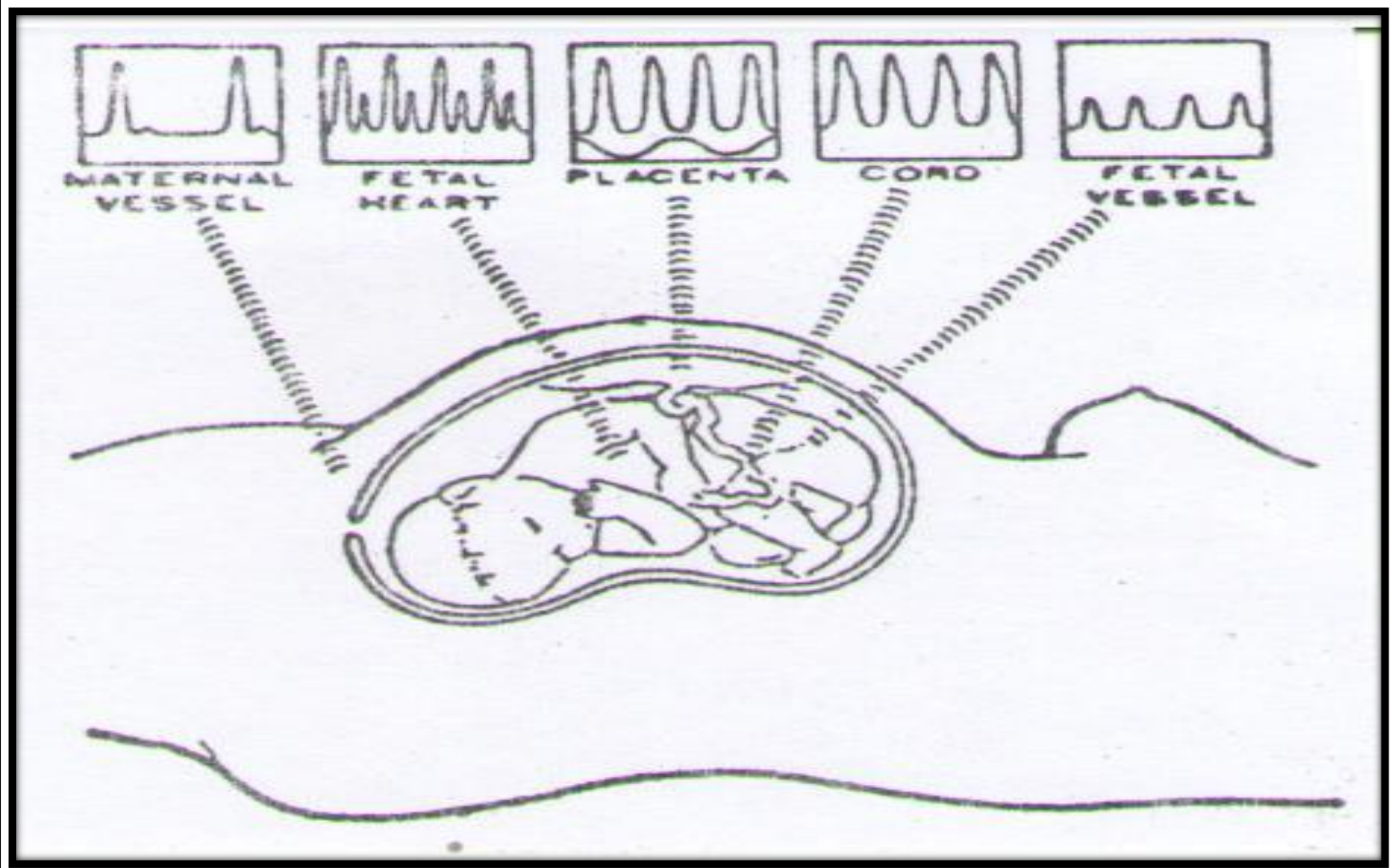

PHYSIOLOGICAL EFFECTS OF ULTRASOUND IN THERAPY

Various physical and chemical effects occur when ultrasonic pass through the body, and they can cause physiological effects. The magnitude of the physiological effects depends on the frequency and amplitude of the sound.

The primary physical effects produced by ultrasound are temperature increase and pressure variations. The primary effect used for therapy is the temperature rise to the absorption of a acoustic energy in the tissue.

Ultrasound waves differ completely from electromagnetic waves, they interact with tissue primarily by microscopic motion of the tissue particles. As a sound wave moves through tissue, the region of compression and rarefaction cause pressure differences in adjacent region of tissue. Stretching occurs in these regions. If the stretching exceeds the elastic limit of the tissue, tearing results. This is why an eardrum can be ruptured by a very intense sound.

In physical therapy the typical intensity is about 1 to 10 W/cm² and the frequency about 1 MHz

Using equation $I = \frac{1}{2} Z (A W)^2$

We find that amplitude of displacement A at 10 W/cm² in tissue is about 10⁻⁶ cm. The maximum pressure amplitude P_o

Equation $I = \frac{P_o^2}{2Z}$

Is approximately 5 atm